

## The “Z” Form: Creating a New Violin Design using Cremonese Building Blocks By Jordan Hess, June 2015

Many modern luthiers trace existing instruments to create the molds and forms used for new violin construction. This method provides these makers with the ability to create relatively accurate copies of existing instruments or to use classic instruments as the starting point for new violin designs.

Rather than tracing existing instruments, I have developed a geometric model that allows me to replicate classic Cremonese models and to design my own models that have a classic Italian feel and sensibility (See Geometry Article...). In addition, I am able to replicate models used by makers in other Northern Italian cities such as Brescia, Venice, Mantua, and Naples, among others.

This article showcases one model which I developed, which I call the 'Z' form. In designing the 'Z' form, I wanted to create an instrument that blended the elegance of the Stradivari forms with the boldness and simplicity of the Del Gesu form (Amati Grand Pattern).

To accomplish this I used the following elements:

- The upper and lower bout geometry is based on the Strad 'P' form geometry (vesicas)
- The internal frame geometry is the same as the 'P' form
- The corner layout and geometry is that of Del Gesu (Amati Grand Pattern)
- The C bout is my own geometry, but is very close to the geometry of Del Gesu.

MAKER MODEL	N. Amati Grand Pattern	Strad P Form	Hess Z Form
CORNER RATIOS	Standard	Modified	Standard
Upper Vertical Constraint	2:3	3:5	2:3
Lower Vertical Constraint	4:5	3:4	4:5
FRAME RATIOS			
LVL:UVL	4:3	4:3	4:3
LVL:1/2LBL	5:4	6:5	6:5
UBL:LBL	4:5	4:5	4:5
CBL Width	1/2LBL	Split between 1/2LBL- 2/3 UBL	Split between 1/2LBL-2/3UBL
VESICA RATIOS			
Lower Vesica	1-1-1	1-1-1 w/ internal mod	1-1-1 w/inter- nal mod
Upper Vesica	1-2-1 with exter- nal mod	2-5-2	2-5-2
C Bout Arc	Upper bout rad.	Lower bout rad.	Radius of A

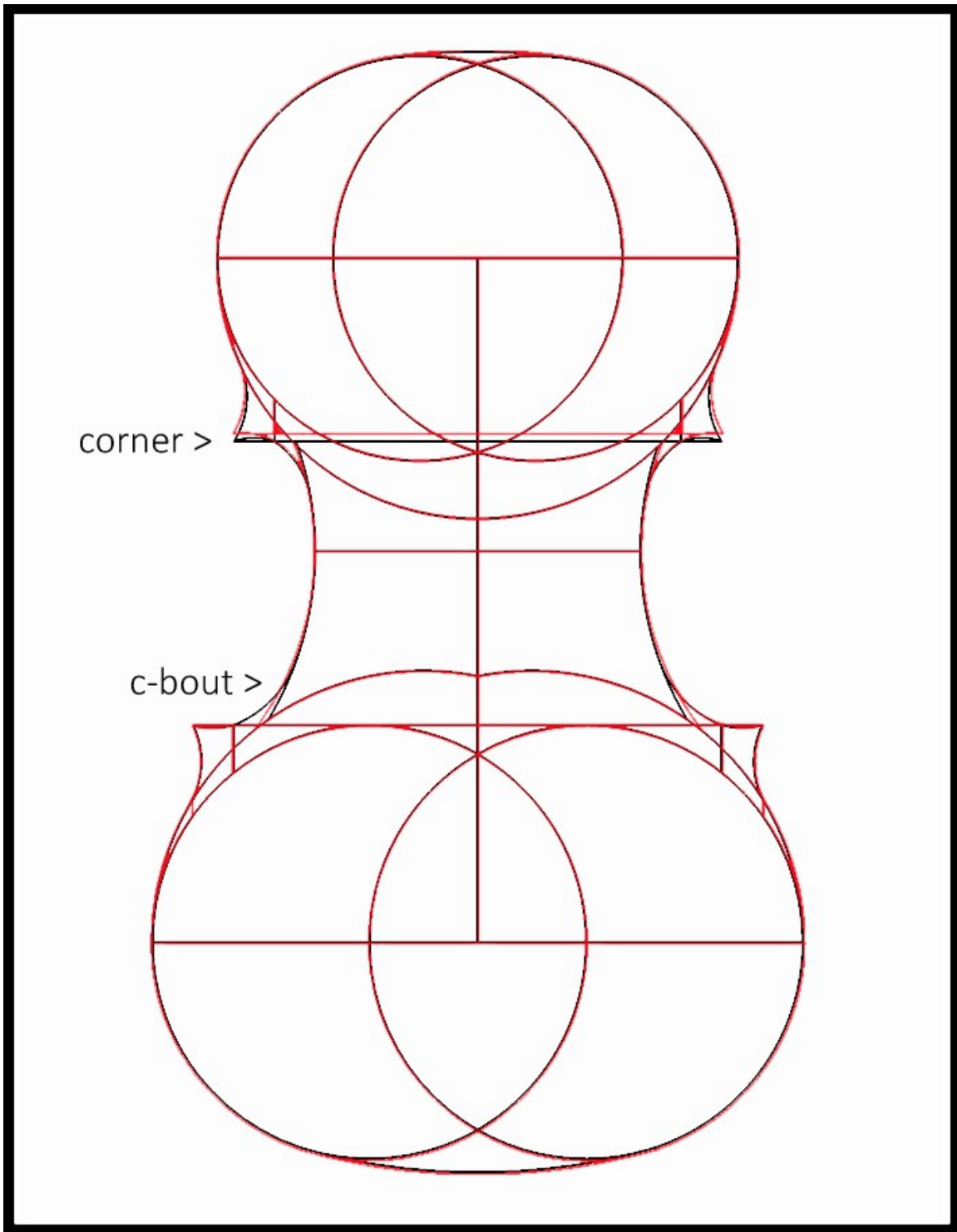

Z form overlaid on the P form (Z form in red)

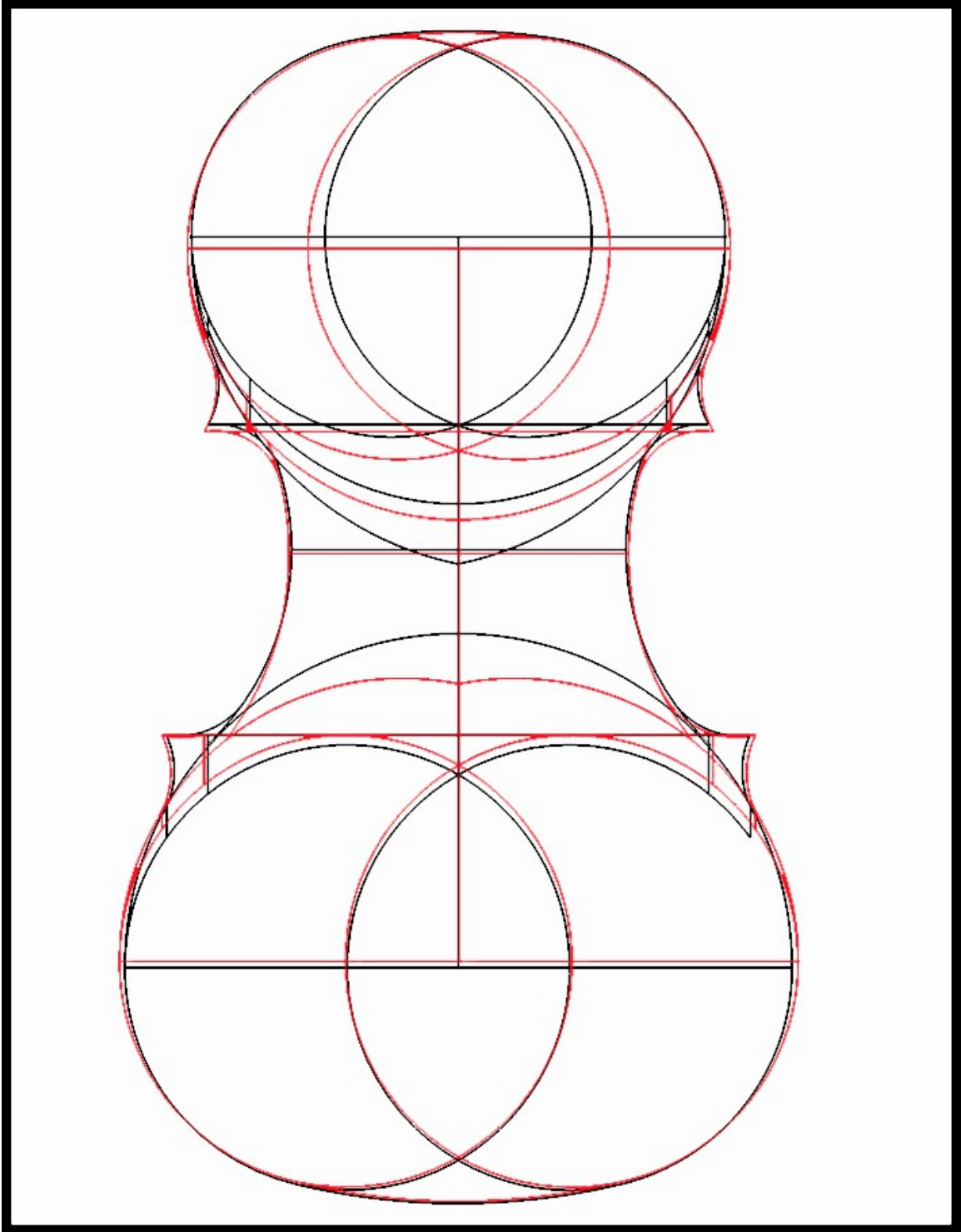

Z form overlaid on Amati Grand Pattern (Z form in red)



Z Form Violin – Front. Made by Jordan Hess May 2015

Jordan Hess ©



Z Form Violin – Back. Made by Jordan Hess, May 2015

Jordan Hess ©